

Elasticized Waterproofing Slurry

- waterproof, tested up to 1.5 bar
- suitable for areas of potential cracking
- tested for use in drinking water
- backfilling after 3 days
- high/low temperature flexibility

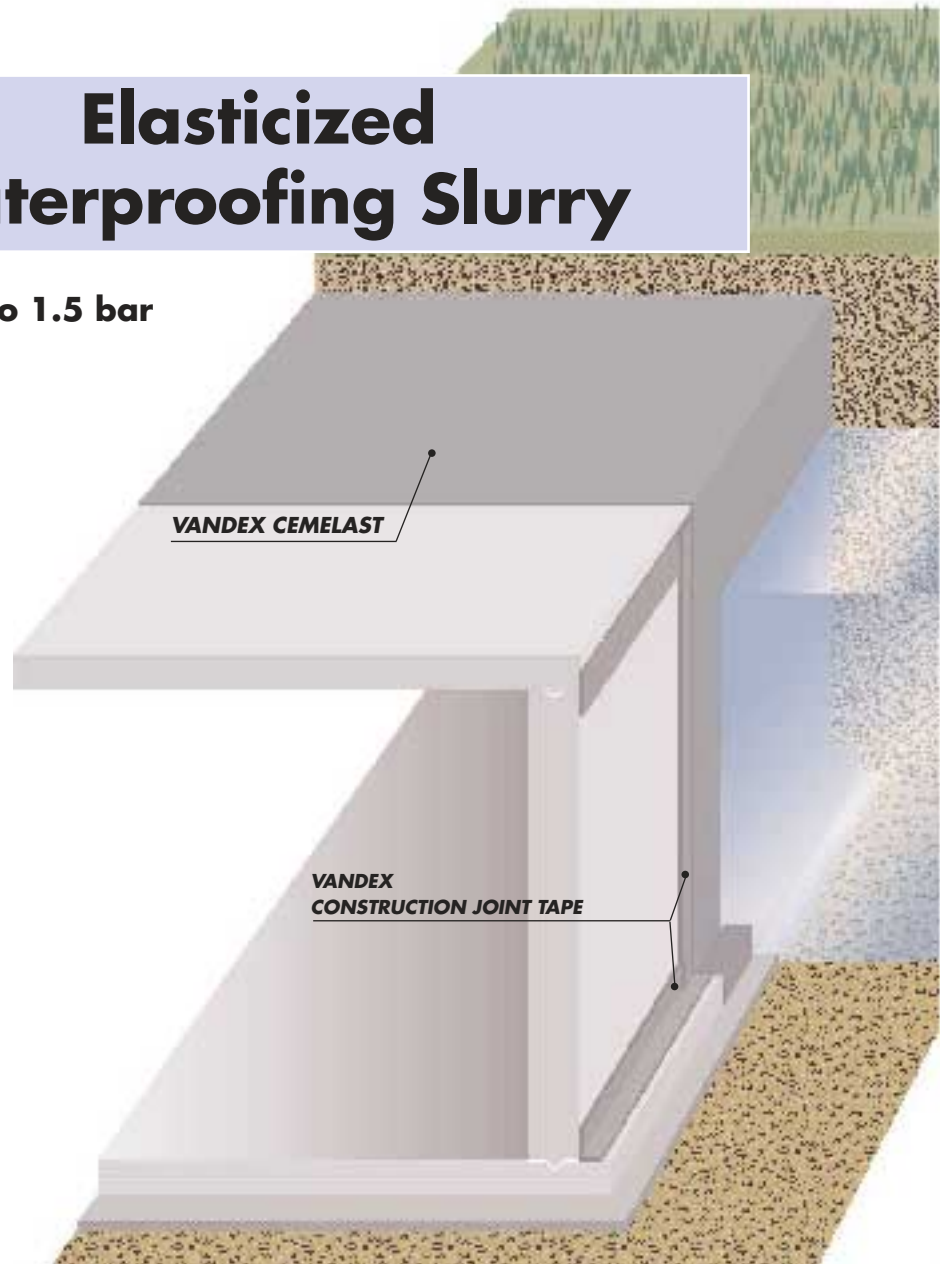

VANDEX CONSTRUCTION JOINT TAPE
external application at horizontal and vertical construction joints.



VANDEX CEMELAST as external waterproofing.



VANDEX CEMELAST as internal waterproofing.

SYSTEM DESCRIPTION

VANDEX CEMELAST is a cementitious, two-component, polymer-modified – and efflorescence-free surface waterproofer with hydrophobic properties. It is resistant to water and moisture, and made by mixing VANDEX BB 75 (dry component) with VANDEX CEMELAST LIQUID.

VANDEX CEMELAST is applied to surfaces such as concrete, masonry and render, which need to be sealed and protected against the ingress of water and moisture. Because of its elastic properties it is used in zones posing cracking or deforming problems.

VANDEX CEMELAST has been tested for use in drinking water reservoirs.

Due to its composition of cement, quartz with well graded aggregate, and special chemical ingredients, as well as the admixture of the polymer component, a waterproof and elastic coating is achieved (tested up to 1.5 bar). VANDEX CEMELAST is suitable for areas of potential cracking. It is compatible with VANDEX BB 75. The initial and final bond of VANDEX CEMELAST to the substrate is excellent, making it suitable for applied application on horizontal as well as vertical surfaces.

WATERPROOFING OF STRUCTURES SUBJECT TO HYDROSTATIC PRESSURE

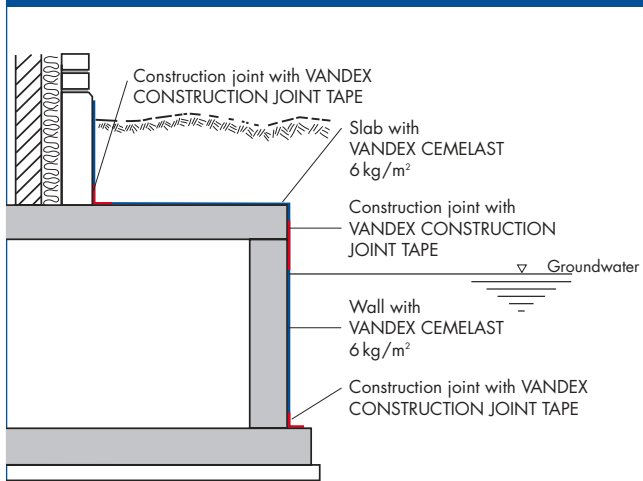

WATERPROOFING OF STRUCTURES NOT SUBJECT TO HYDROSTATIC PRESSURE

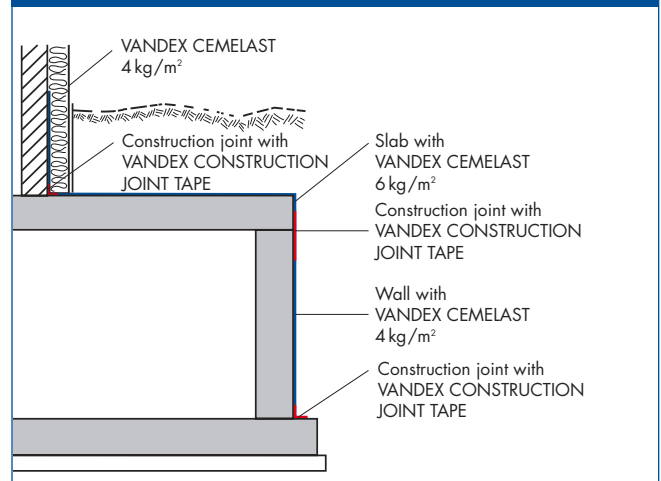

APPLICATION

1 Place the VANDEX CONSTRUCTION JOINT TAPE onto the first coat of VANDEX BB 75 E or VANDEX CEMELAST (3 kg/m², 1.5mm). Then, embed both fabric edges of the tape in the mix.



3 VANDEX CEMELAST applied in two coats by spray application.



2 Overcoat VANDEX CONSTRUCTION JOINT TAPE with a second coat of VANDEX BB 75 E or VANDEX CEMELAST (3 kg/m², 1.5mm).



4 VANDEX CEMELAST trowel application in two coats.



CONSUMPTION VANDEX CEMELAST

Condition of loading	Consumption VANDEX CEMELAST in two coats	Total layer thickness
Ground moisture Film of surface water and see page	4 kg/m ²	2 mm
Water under pressure, groundwater	6 kg/m ²	3 mm

TECHNICAL DATA

	VANDEX CEMELAST (wet mix)	VANDEX CEMELAST (hardened)
Colour	grey	grey
Density of wet mix	approx. 1.65 kg/l	–
Setting time	approx. 2–4 hours	
Adhesive strength		1.0–1.2 N/mm ²
Elongation at rupture at 20° C	–	13%
Crack bridging capacity 20° C to -20° C	–	0.4 mm

For further information please refer to VANDEX CEMELAST and VANDEX CONSTRUCTION JOINT TAPE data sheets.
www.vandex.com