



Vandex[®]

RAPID SYSTEM

Time is important...





VANDEX RAPID SYSTEM – true problem solver

The four products in the VANDEX RAPID SYSTEM range are true problem solvers. Their waterproofing properties develop even when in contact with running water. Only hours after application the products are capable of withstanding maximum load, resulting in minimal interruption to the refurbishment process. Furthermore the products are resistant to domestic sewage.

Chemically resistant waterproof coating – in a few hours

Due to its composition of cement, quartz with graded grain-size distribution and special chemical ingredients of an inorganic nature, the VANDEX RAPID SYSTEM product range cures completely within a few hours. The waterproof coating formed is highly resistant to abrasion and chemicals.

Repair or maintenance – no compromise

In sewage systems there are many areas such as manholes, collectors and treatment plants which require repair or maintenance, but often can only be shut down for a short period of time. A repair and refurbishment system allowing this with a downtime as low as just 4–6 hours is often required. The VANDEX RAPID SYSTEM offers this without compromising the quality of the repairs.

Areas of application

- Manholes
- Sewers
- Collectors
- Treatment plants
- Pipe junctions/connections
- Tunnels
- Below ground structures

Advantages

- ✓ Rapid setting
- ✓ Cures in a few hours
- ✓ Immediately resistant to load
- ✓ Short and predictable downtime
- ✓ Designed for use in sewers and manholes

Typical damage to repair

- Ground water ingress
- Damaged joints
- Cracks
- Corroded concrete
- Leaking pipes and junctions





The leaking area



Substrate preparation



Sealing leaking joints



Sealing of leaking points



Applying a coved fillet at wall / floor junction



Waterproofing the surface

Basement

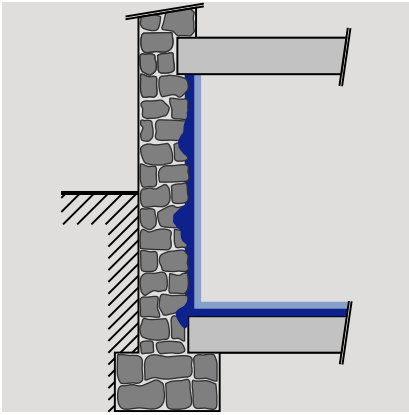

Pipe Inlet

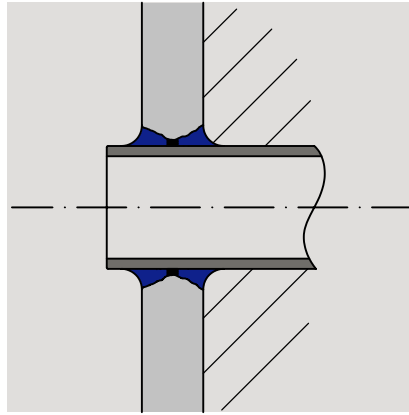

Manhole

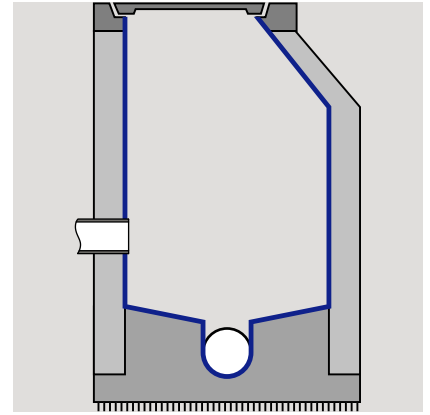

THE VANDEX RAPID SYSTEM

VANDEX RAPID S

Rapid waterproofing slurry

- After 3 hours – resistant to load
- For concrete, masonry and render
- Suitable for sealing and interior coating
- Designed for use in sewers and manholes

VANDEX RAPID M

**NEW – DRINKING WATER
APPROVED IN GERMANY**

Rapid waterproof repair mortar

- After 1 hour – resistant to load
- Waterproof at 10mm layer thickness
- For horizontal and vertical application
- Designed for use in sewers and manholes

VANDEX RAPID XL

Rapid reprofiling mortar

- After 2 hours – resistant to load
- 100mm applicable in one working cycle
- Fibre reinforced
- Designed for use in sewers and manholes

VANDEX RAPID 2

Rapid waterproof plugging compound

- 2 minutes setting time
- Stops flowing water
- Installation of pipes in manholes
- Designed for use in sewers and manholes



The information contained herein is based on our long-term experience and the best of our knowledge. We can, however, make no guarantee since for a successful outcome, all circumstances in an individual case must be taken into consideration. Indications of quantities required are only averages which in certain cases might be greater.

Vandex®

HEADOFFICE AND INTERNATIONAL SALES:

VANDEX INTERNATIONAL LTD

P.O. Box, CH-4501 Solothurn/Switzerland
Phone +41 32 626 36 36, Fax +41 32 626 36 37
E-mail info@vandex.com www.vandex.com

PRODUCTION AND SALES GERMANY/AUSTRIA:

VANDEX ISOLIERMITTEL-GESELLSCHAFT m.b.H.

Postfach 1406, D-21487 Schwarzenbek/Germany
Telefon +49 4151 89 15-0, Telefax +49 4151 89 15 50
E-mail info@vandex.de www.vandex.de

CONCRETE PROTECTION AND WATERPROOFING

